

F200

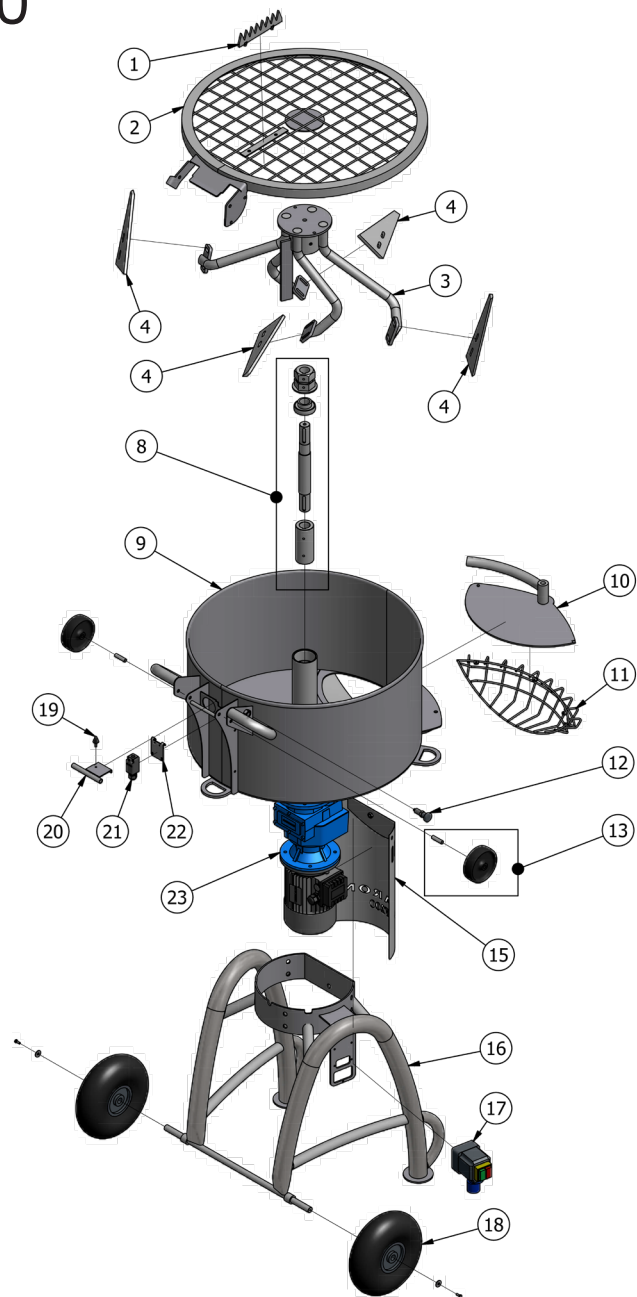

POS.	PART NO.	DESCRIPTION
1	50640	Sack knife complete
2	50549	Cover
3	50425	Mixer head (without shovels)
4	50440	Metal shovels, complete set (4 pcs)
8	50652	Drive shaft, complete
9	50511	Container
10	50375	Trapdoor, complete
11	50355	Outlet protection
12	50328	Positioning bolt
13	50343	Transportwheel, complete (1 pc)
15	50566	Engine cover
16	50524	Frame
17	50303	Main switch, 3x380V 4-6A, phase indicator
18	50340	Wheel, 20x75 (1 pc)
19	50327	Rubber damper
20	50603	Plate for cover switch
21	50326	Mechanical cover switch
22	50600	Bracket for cover switch
23	50203	Motor + gear, 2.2kW 3x380V, Fabrika
	50276	Starting contact 4kW K3 for main switch
	50278	Thermo relay for main switch

POS.	PART NO.	OTHER SPARE PARTS
	50467	Rubber shovels, complete set (4 pcs)
	50224	Motor, 2.2kW 3x380V, Fabrika
	50223	Motor, 1.8kW 110V, Fabrika
	50231	Gear for E200/M200 Fabrika
	50305	Main switch, 110V 20-25A
	50263	Main relais, 20-25A
	50270	Undervoltage relais, 110V
	50108	Extension cable, 3x380V CEE, 5m
	50106	Extension cable, 3x380V CEE, 10 m
	50679	Dust cover (lid)